

Alex 44 6x6

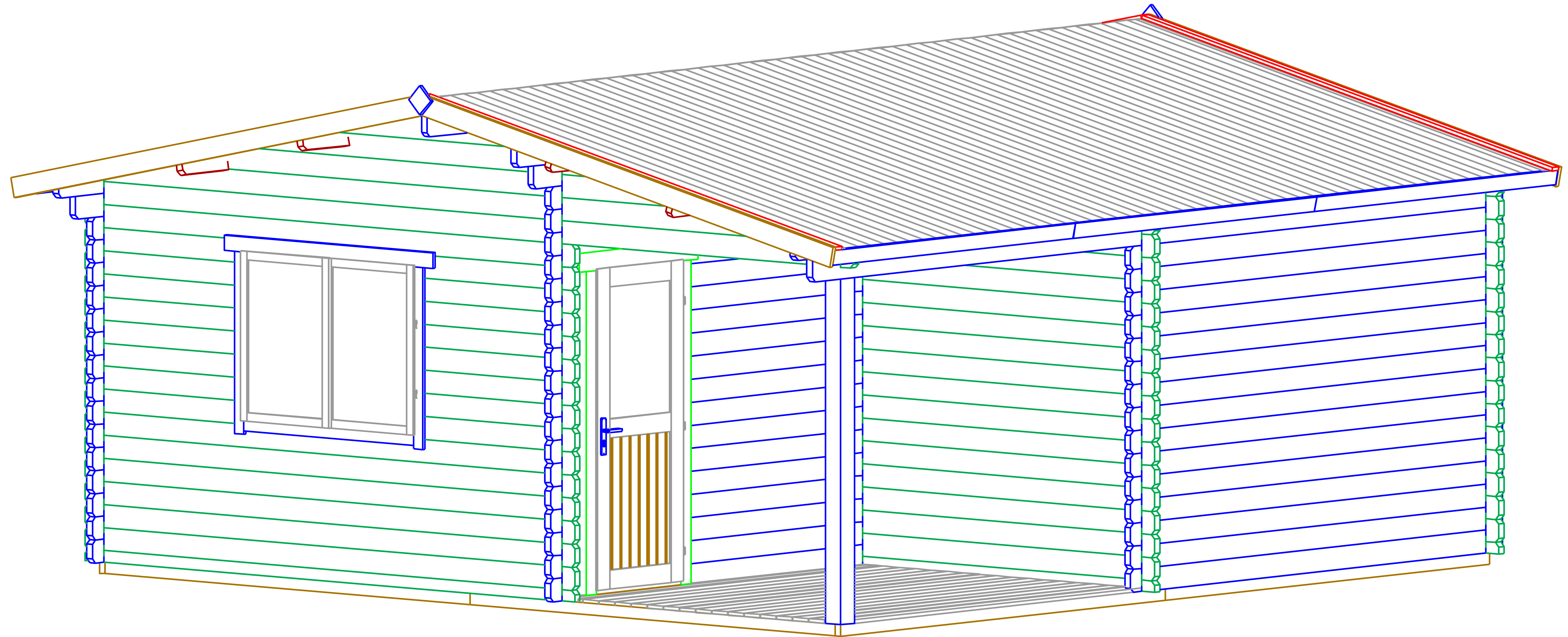

Alex 44 6x6

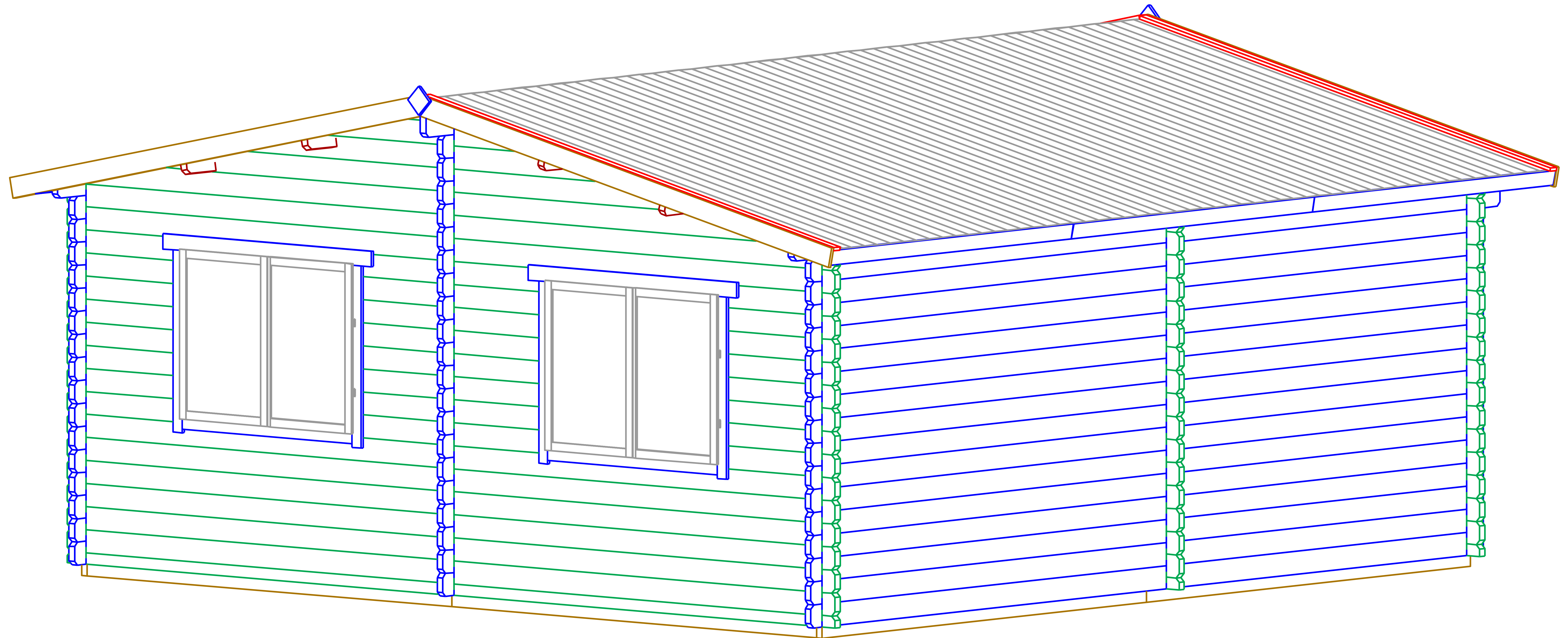

Alex 44 6x6

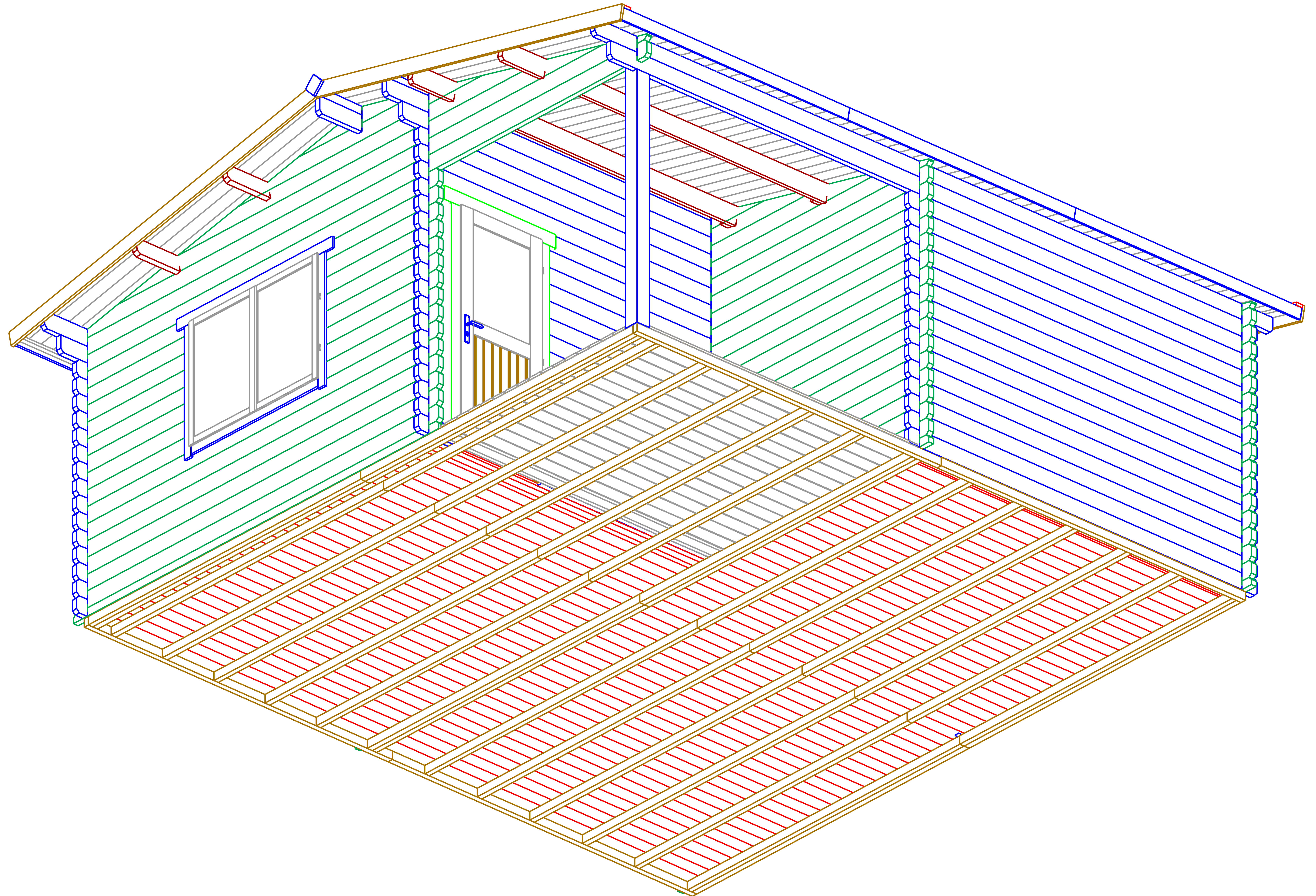

Alex 44 6x6  
Plan

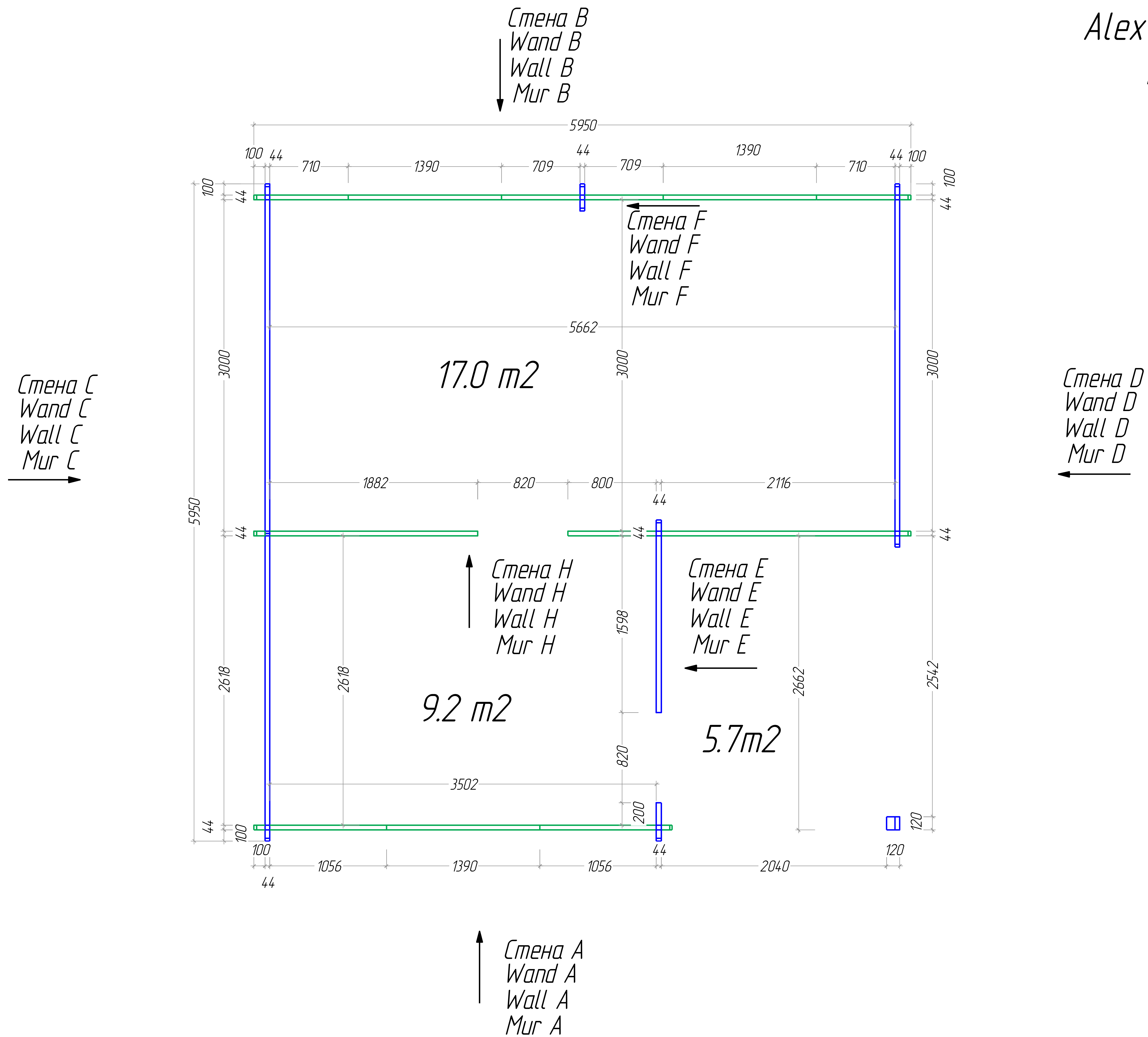





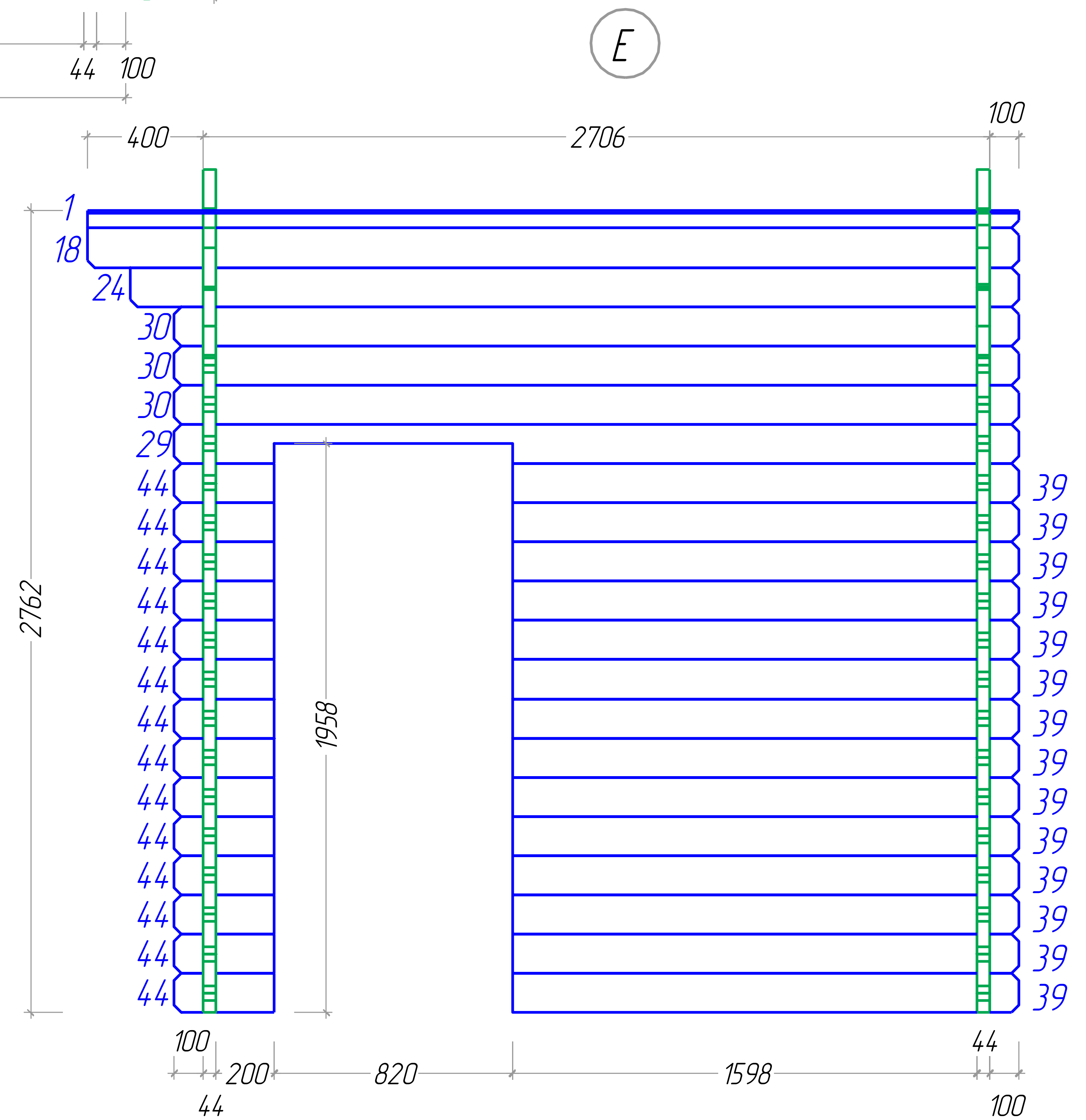
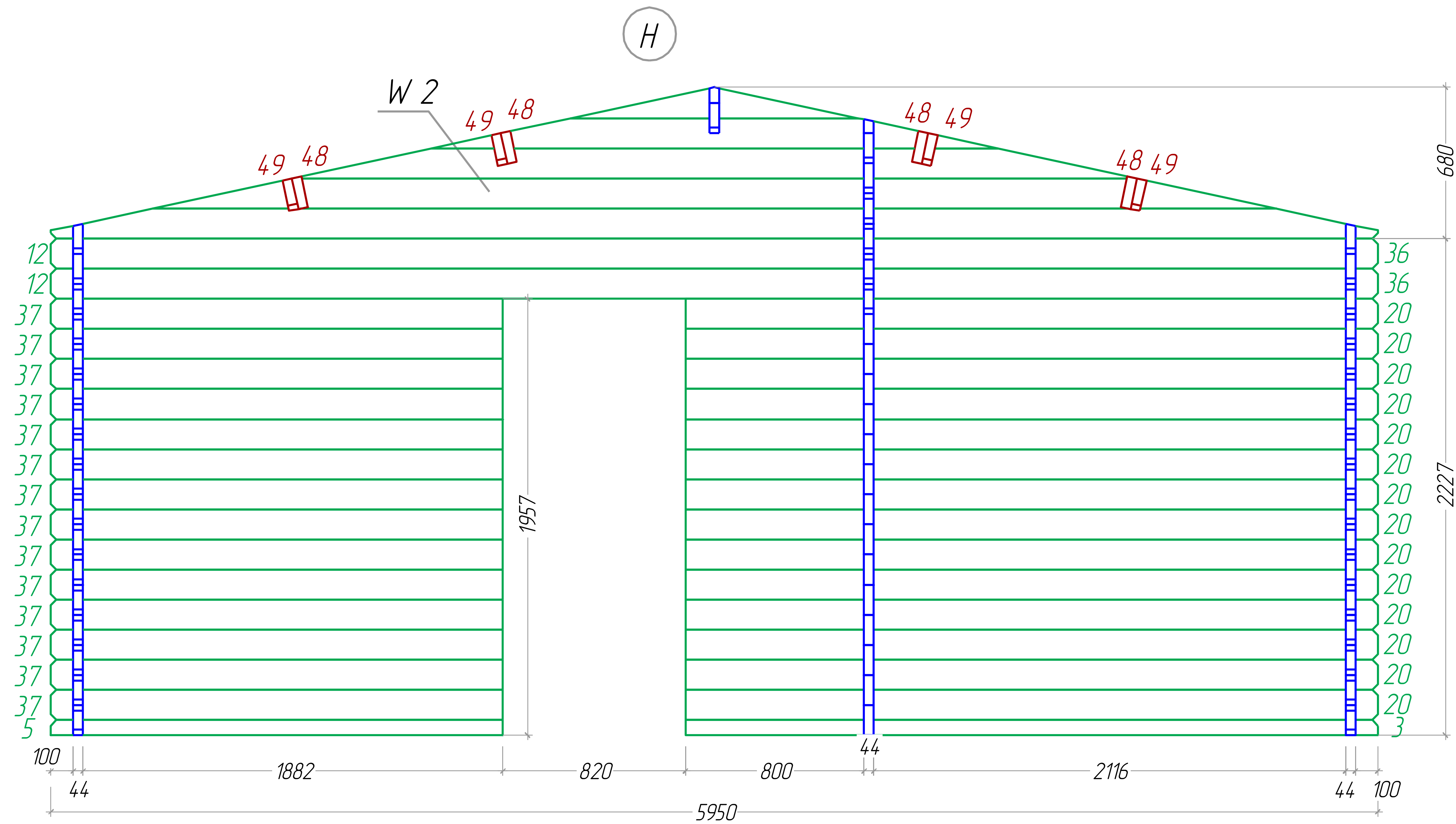

F

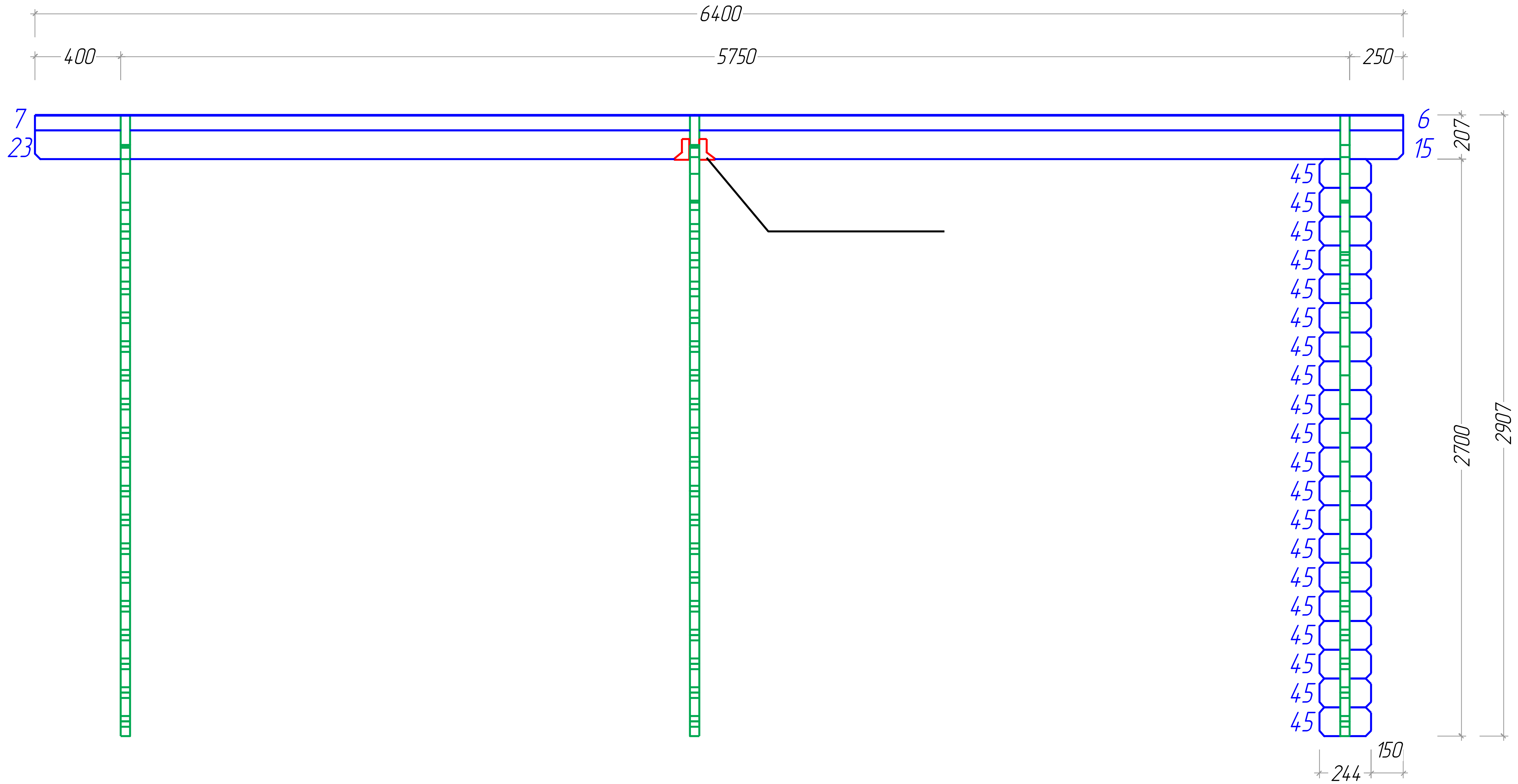



Alex 44 6x6

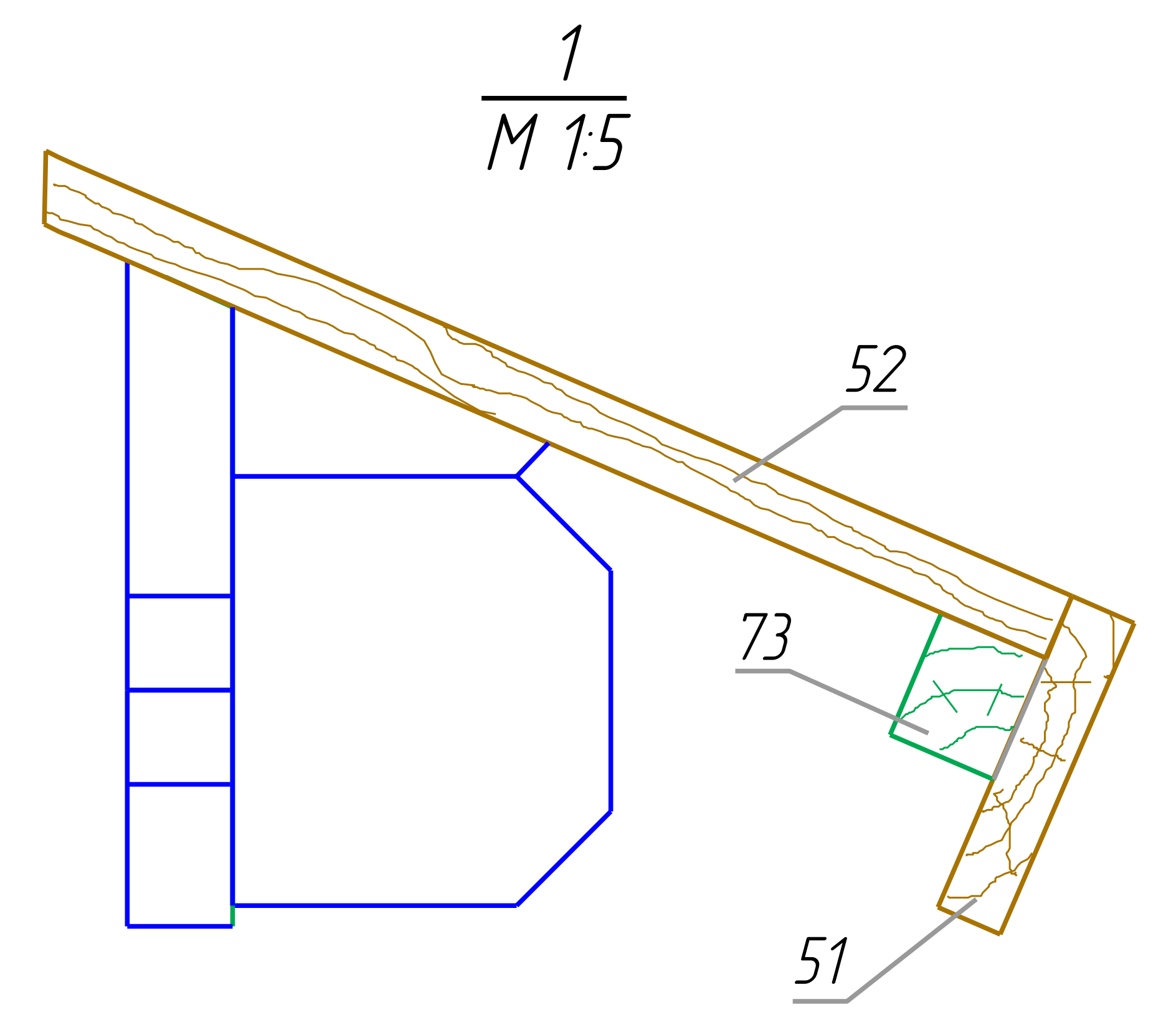
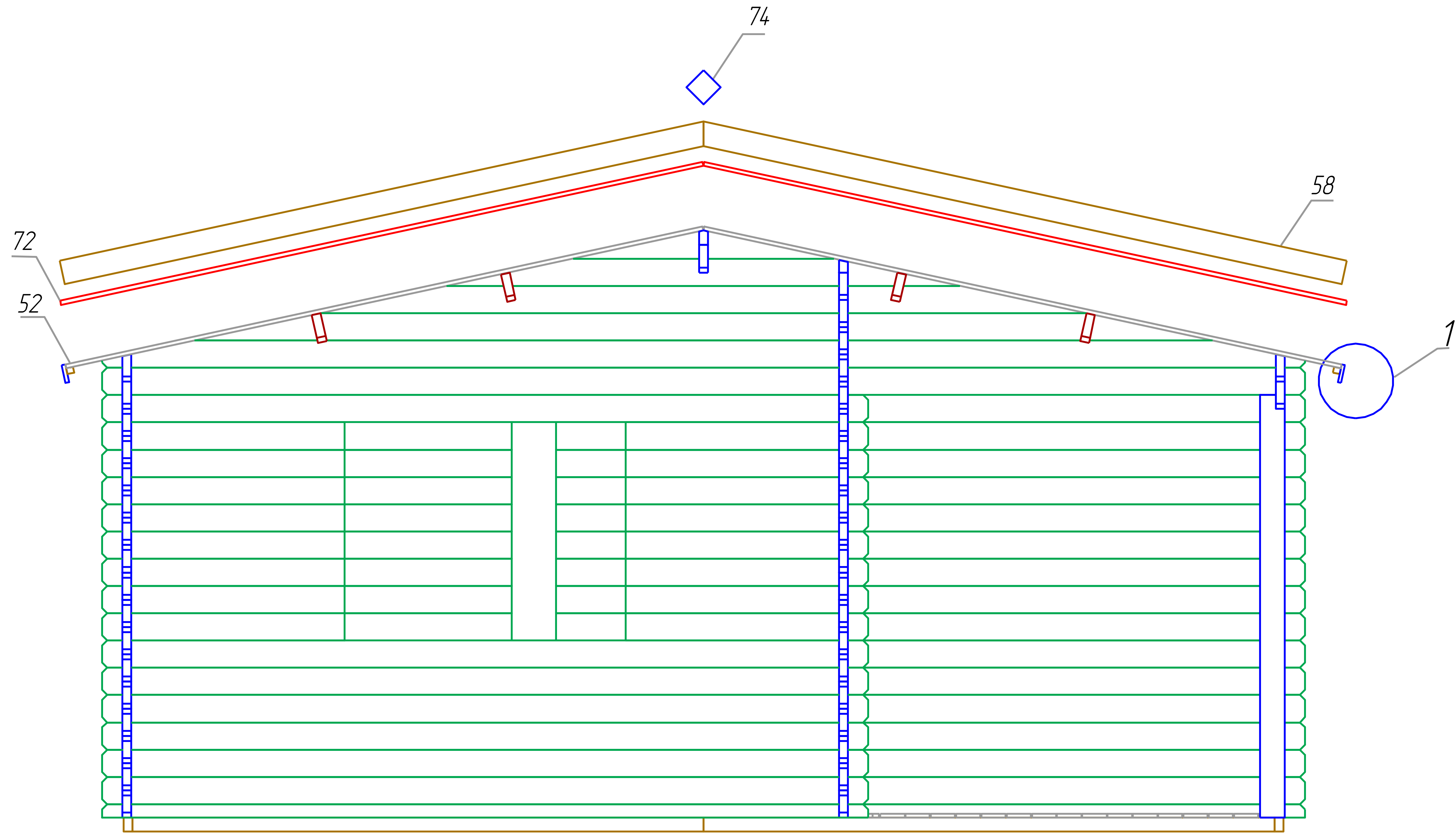

Alex 44 6x6

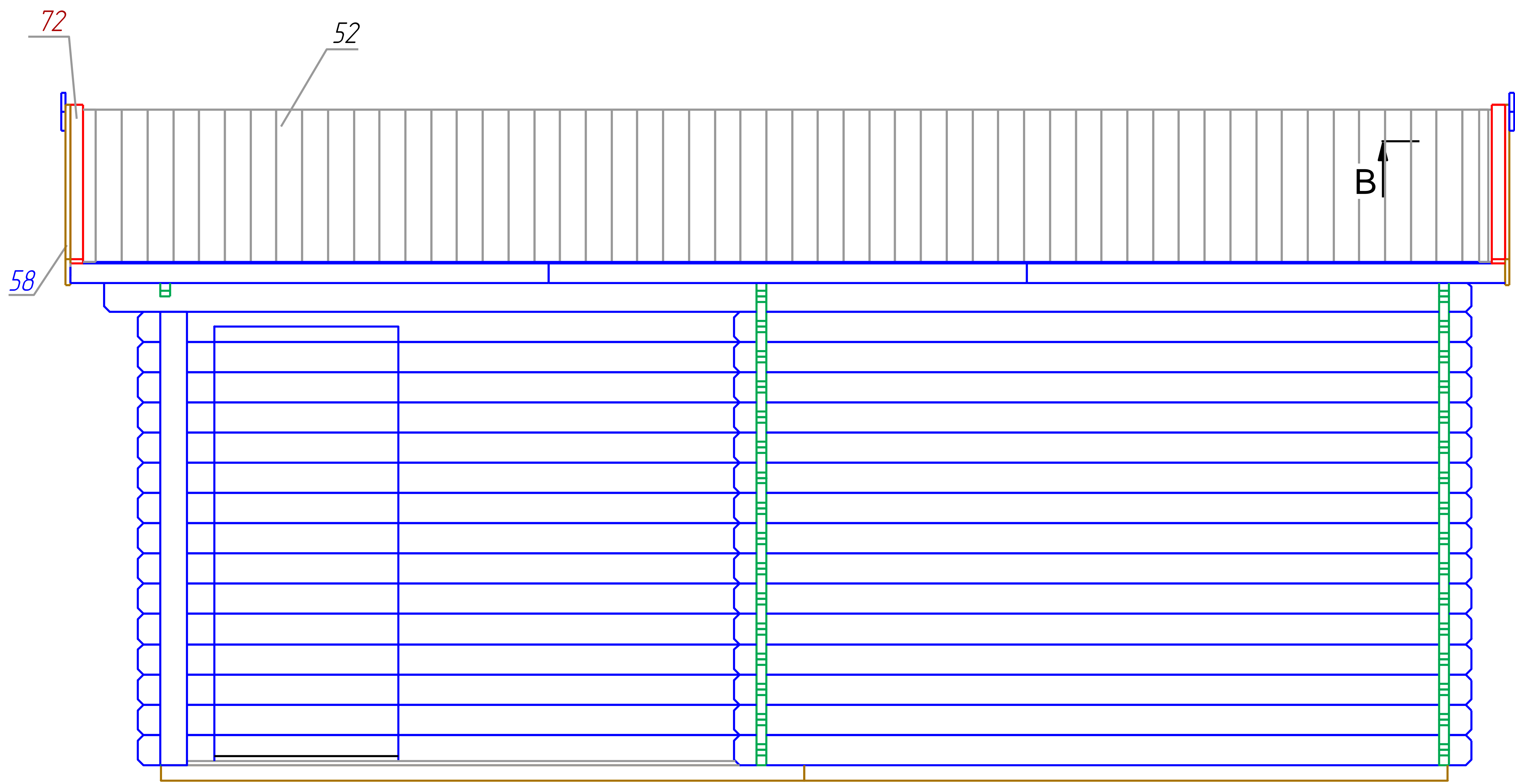

B

$\frac{B-B}{M 1:5}$

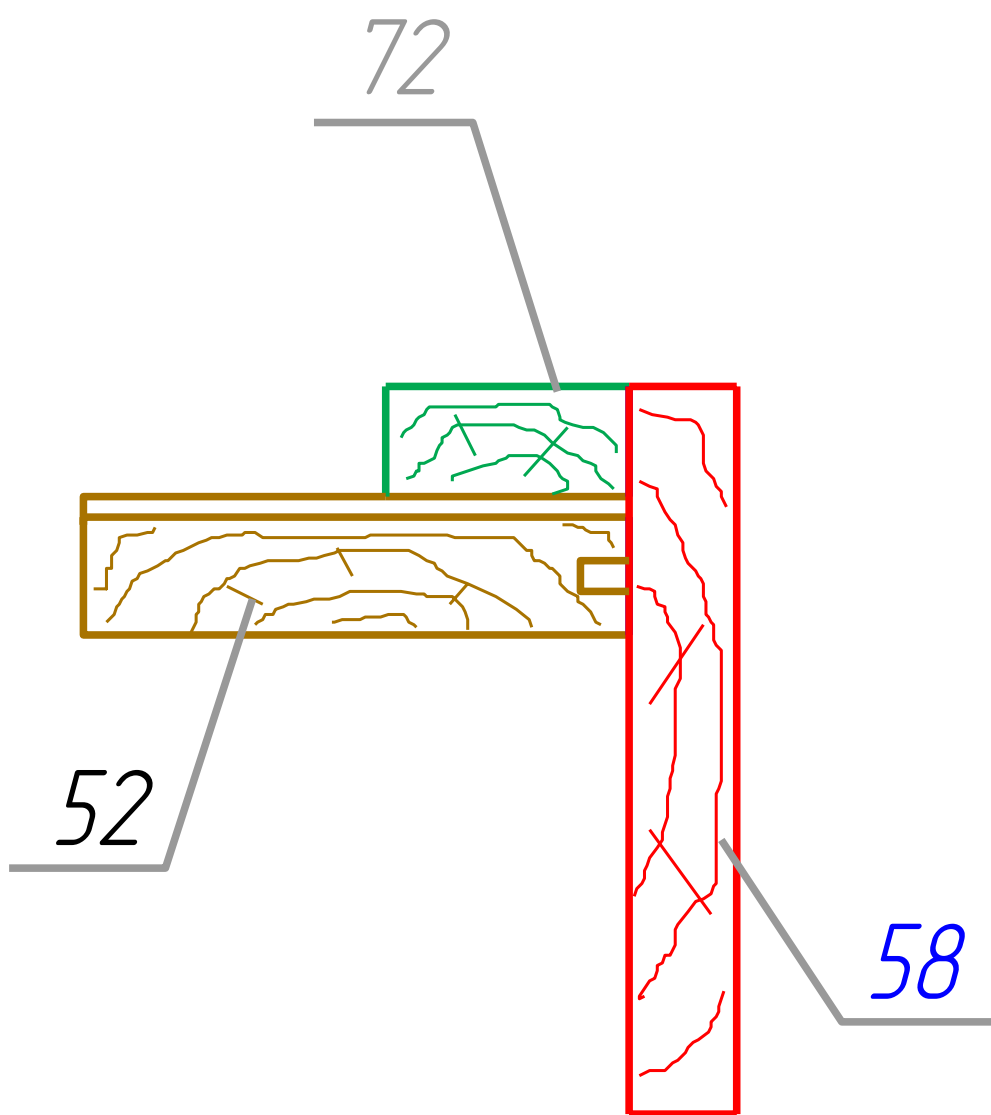

# Alex 44 6x6



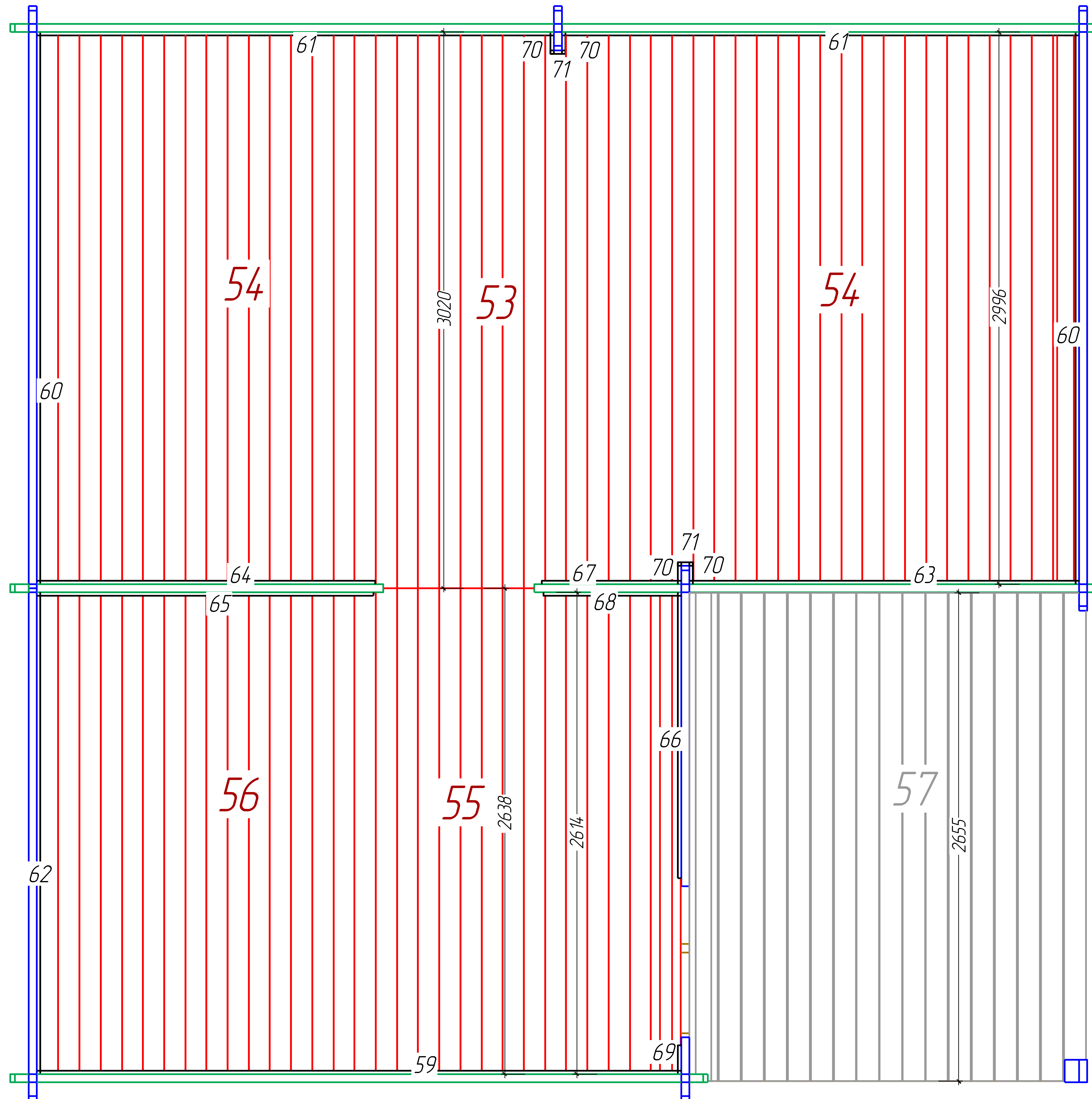



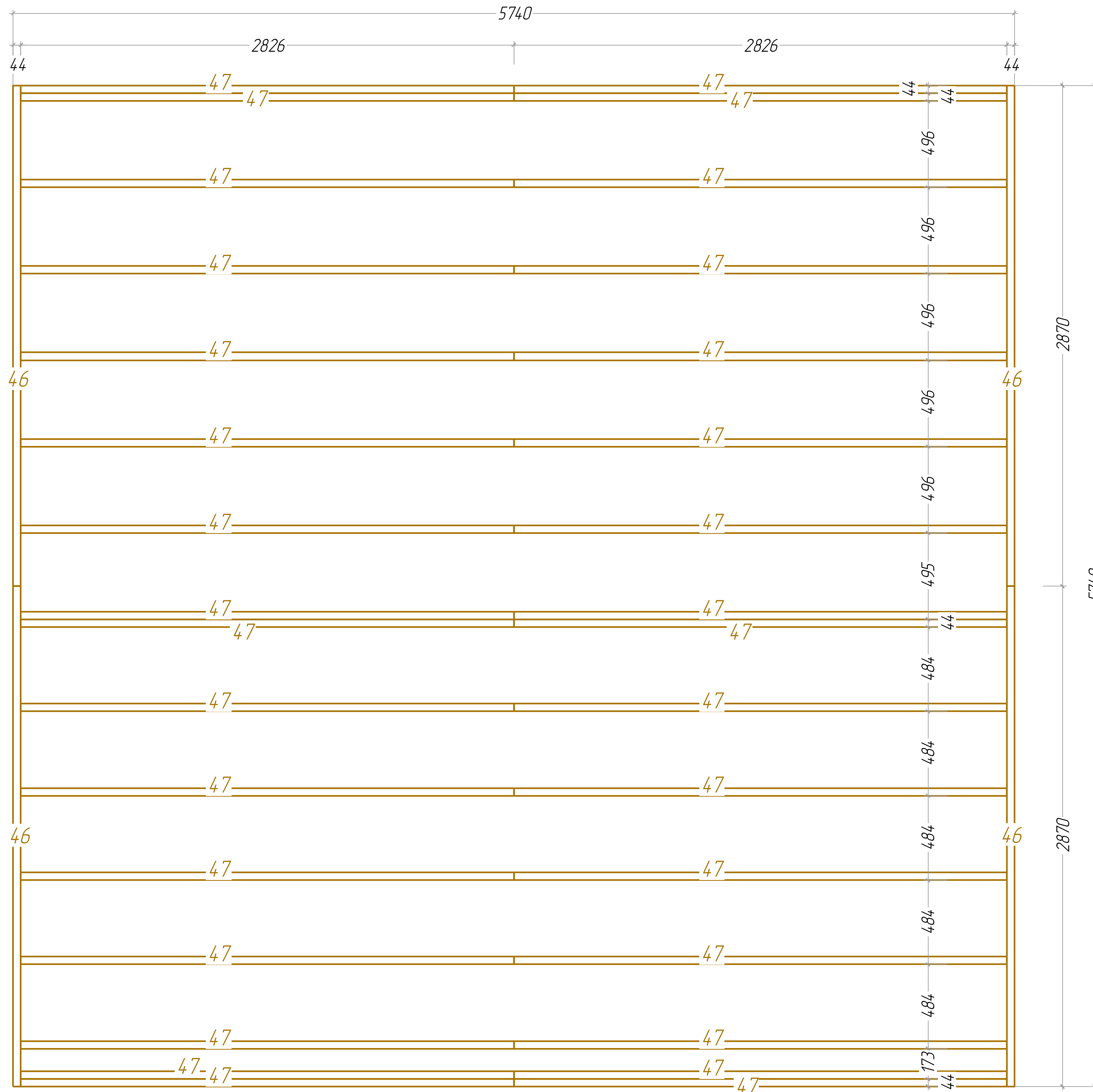

Boarding joist plan  
Trummplan  
Lambourde plan

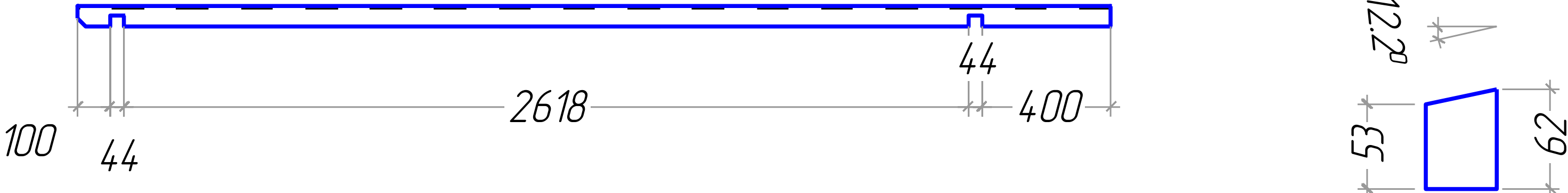
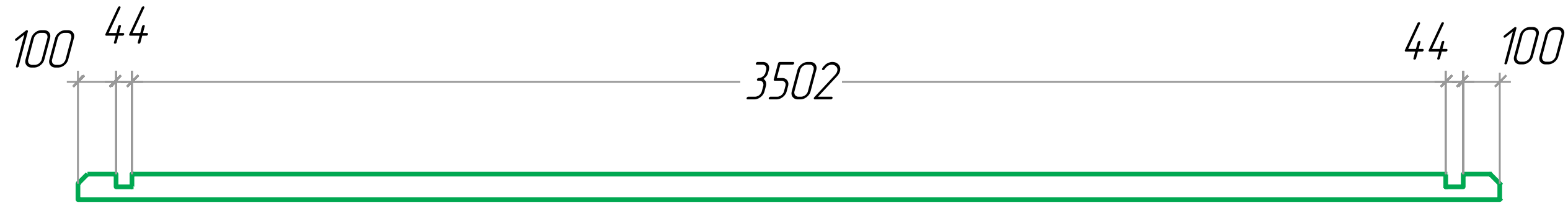

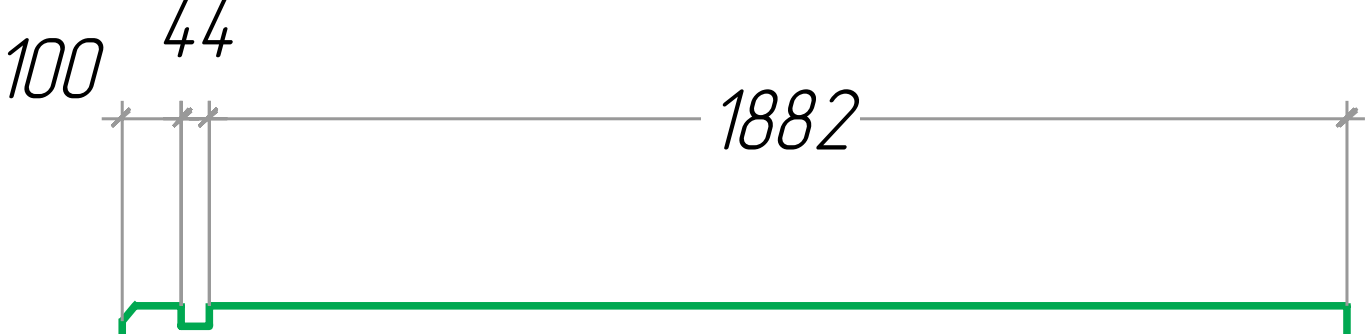

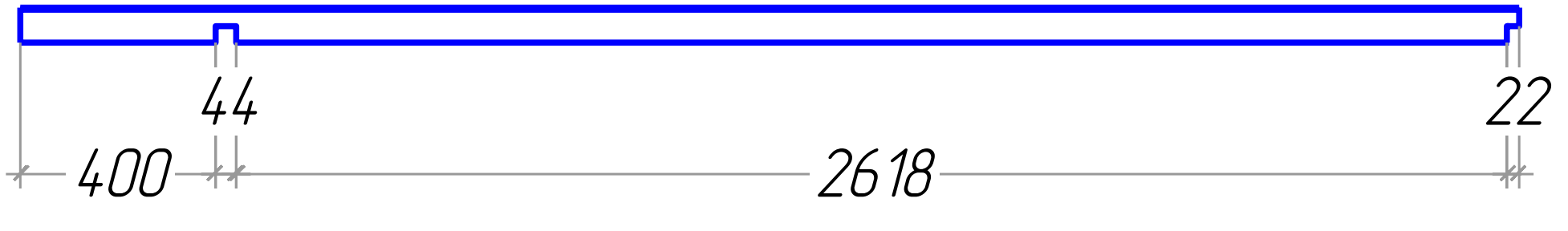

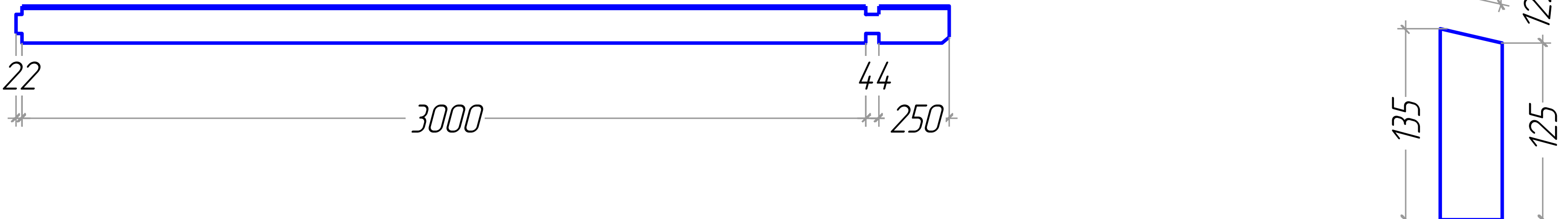
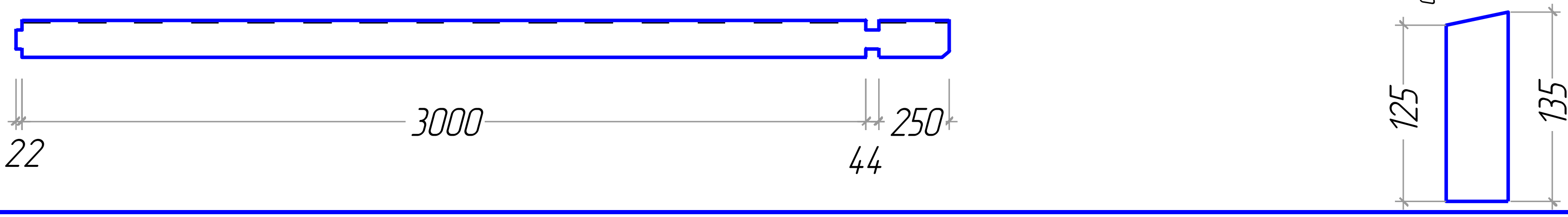
# Alex 44 6x6

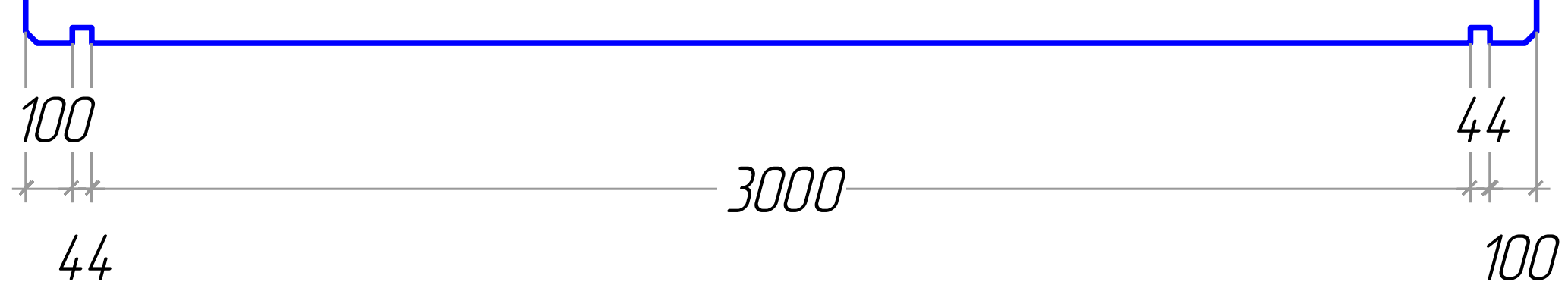

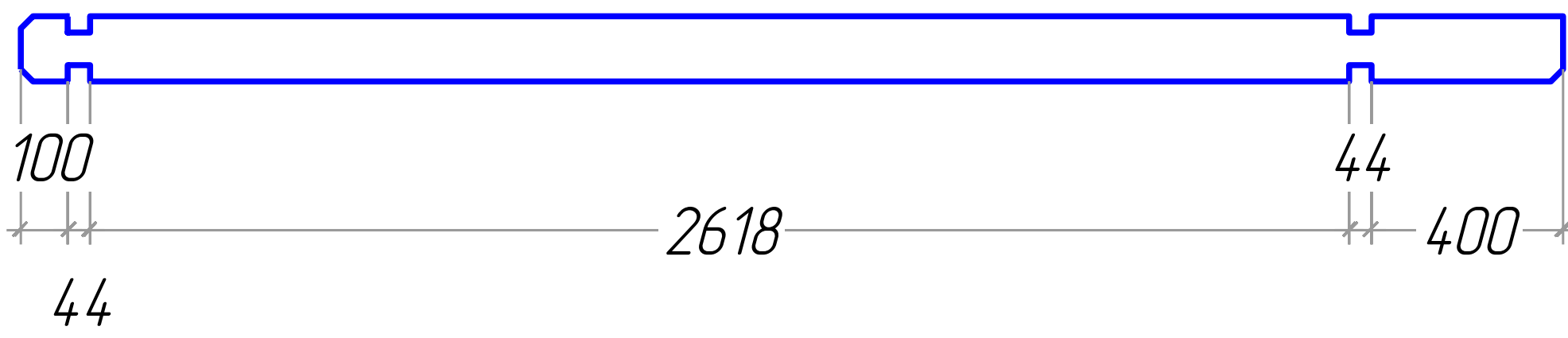
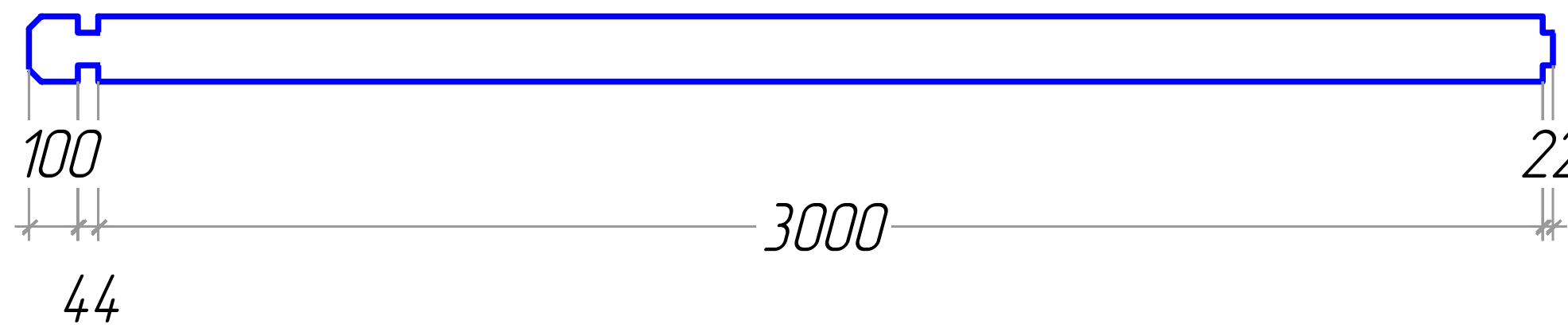
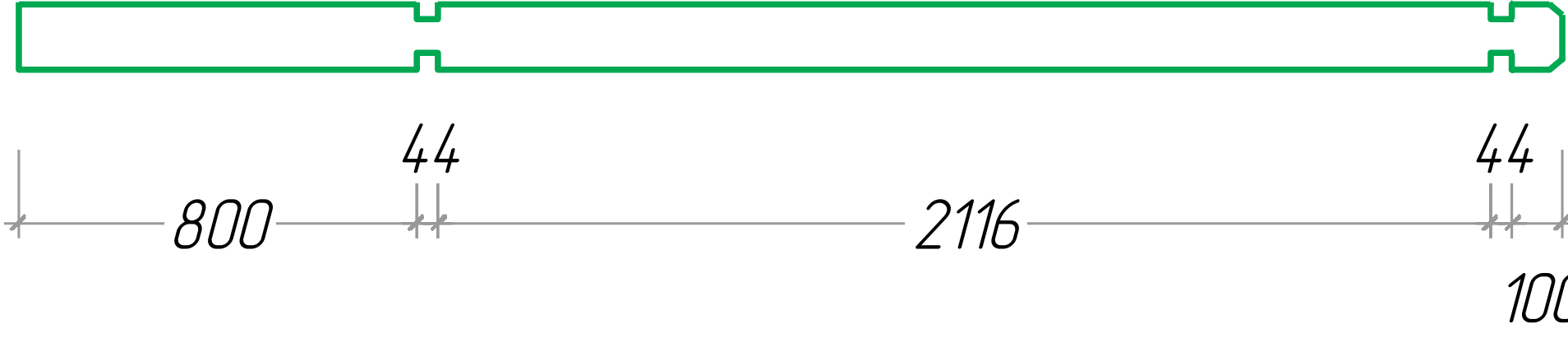
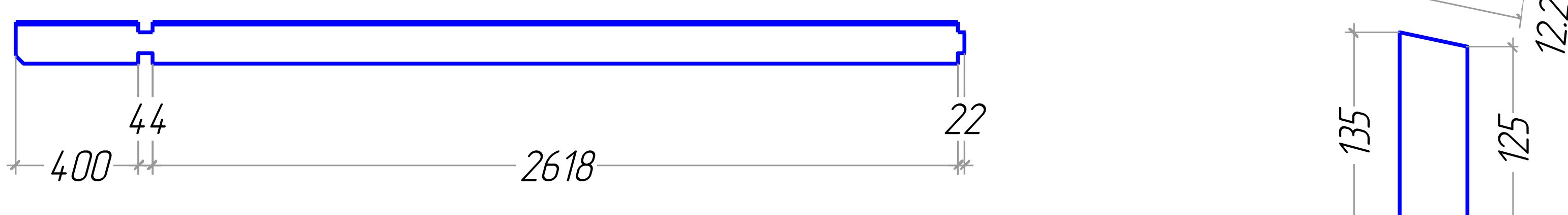
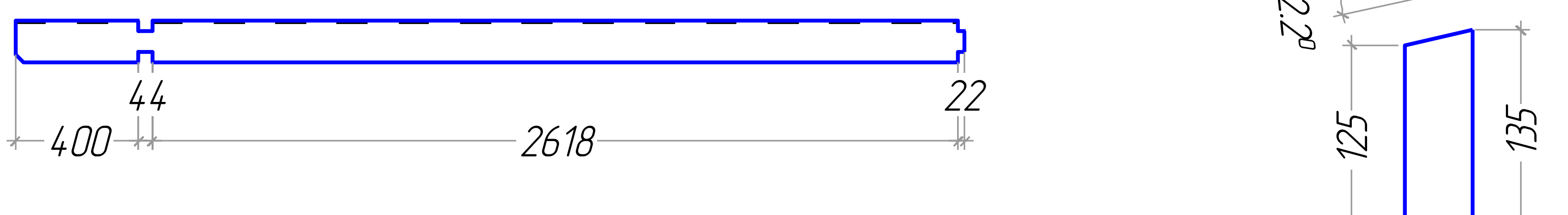
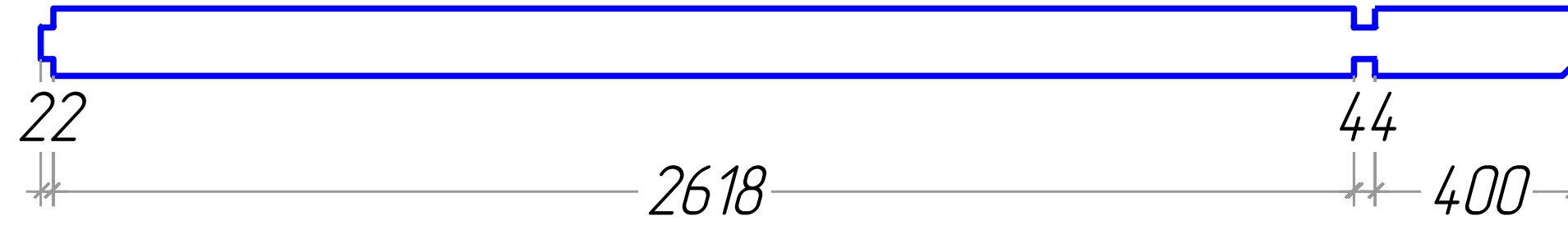
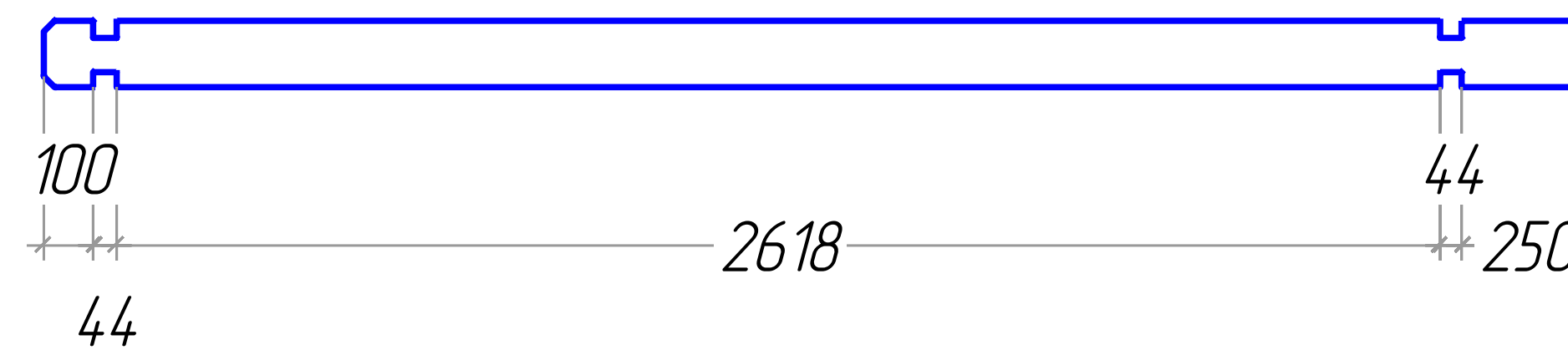
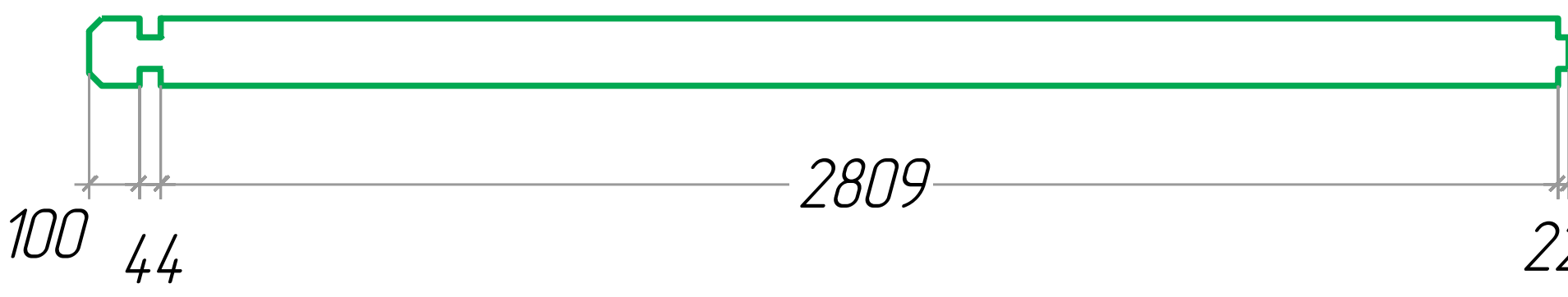
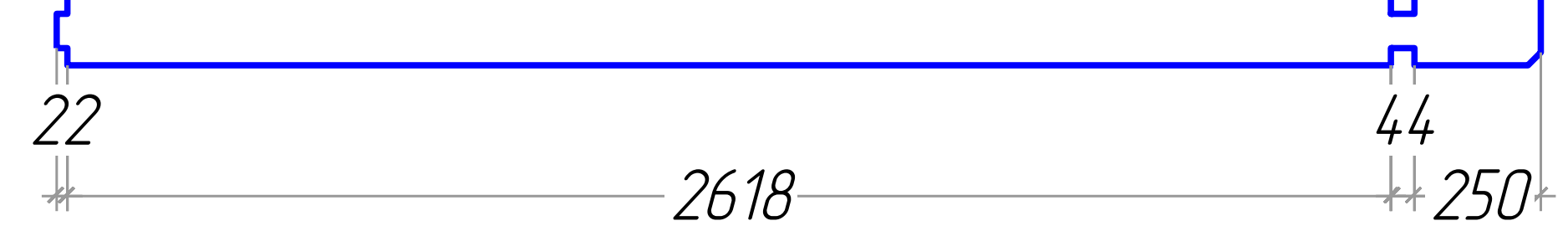
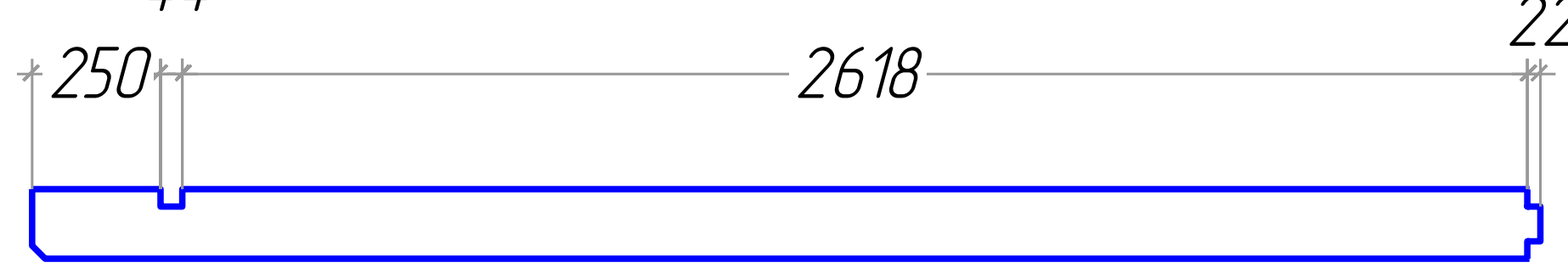
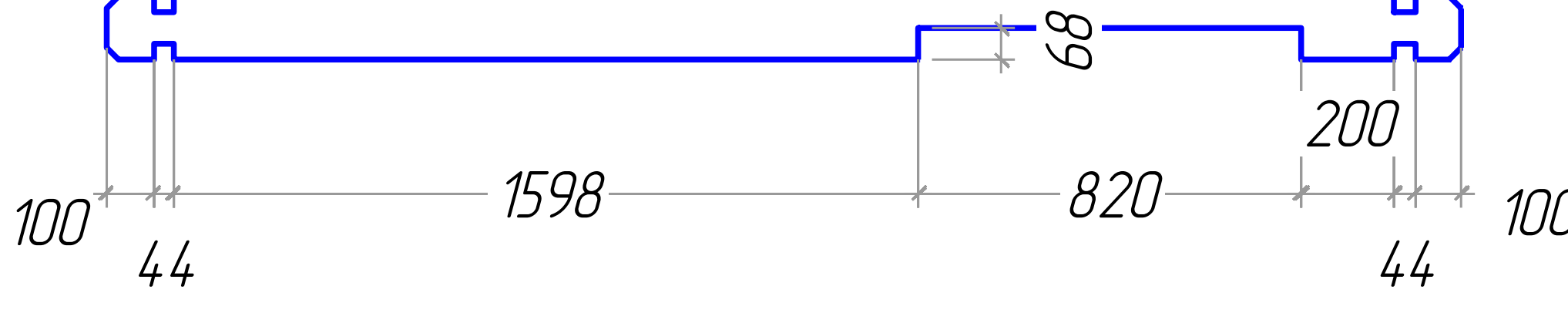
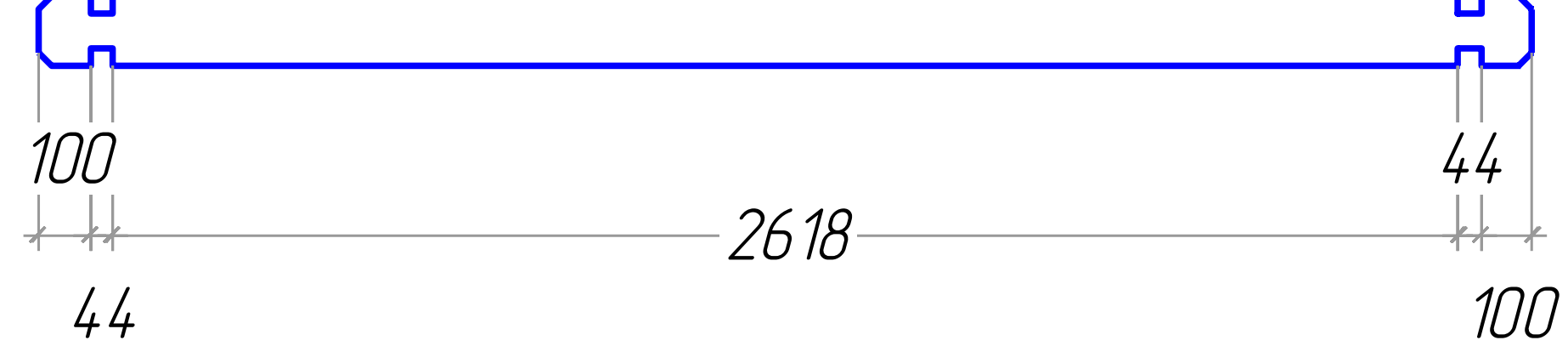
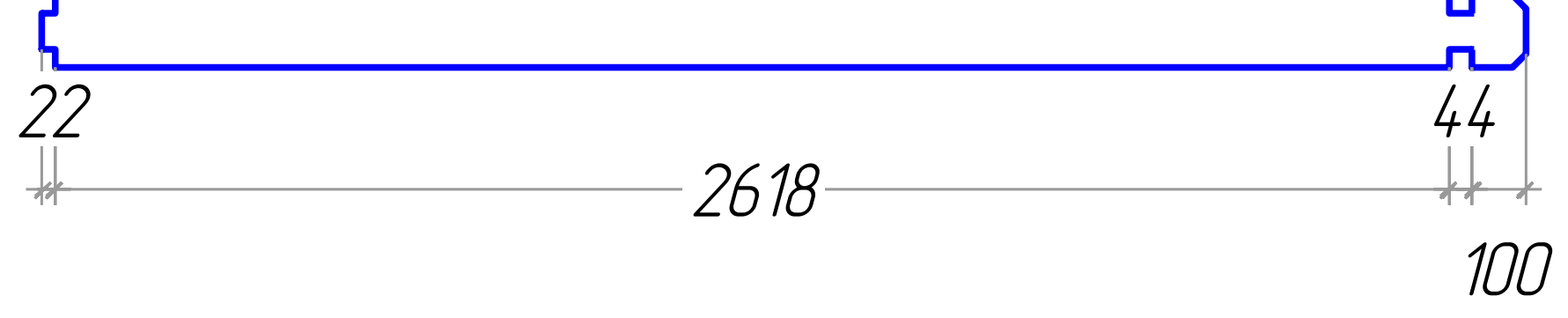

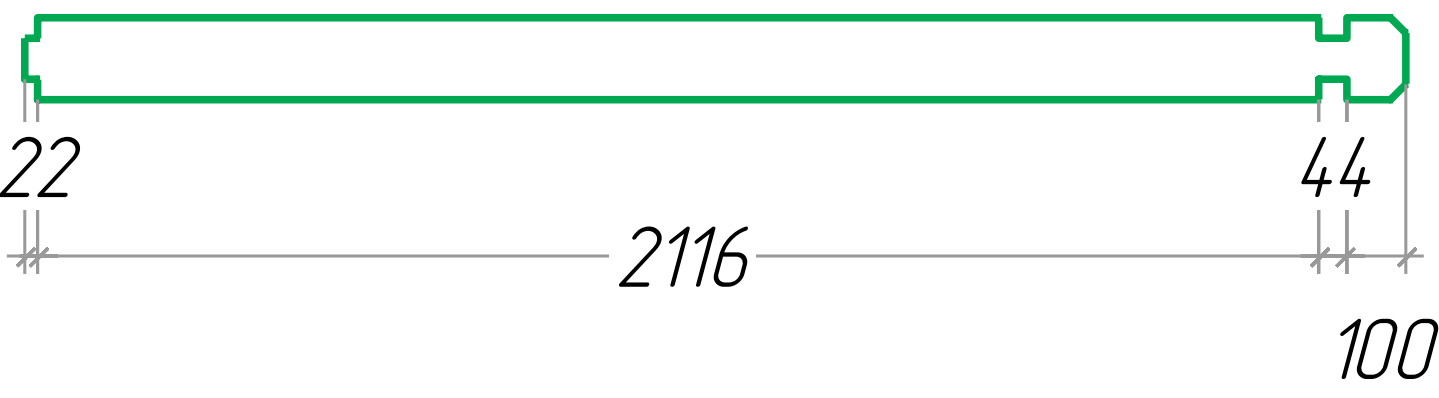
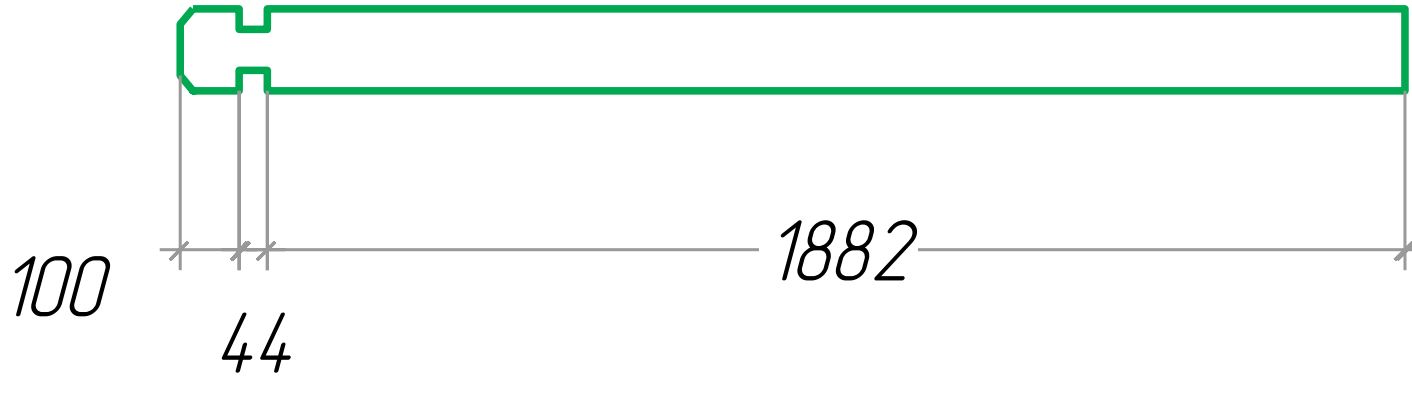
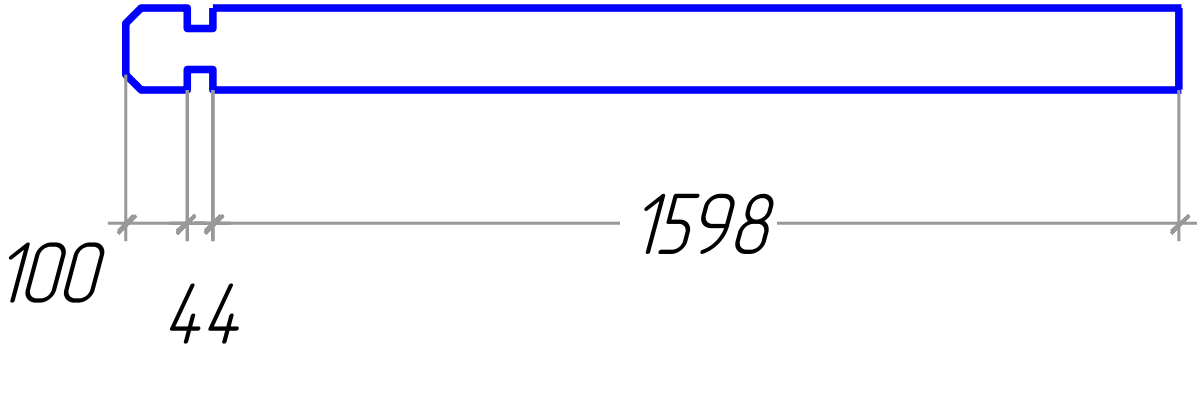
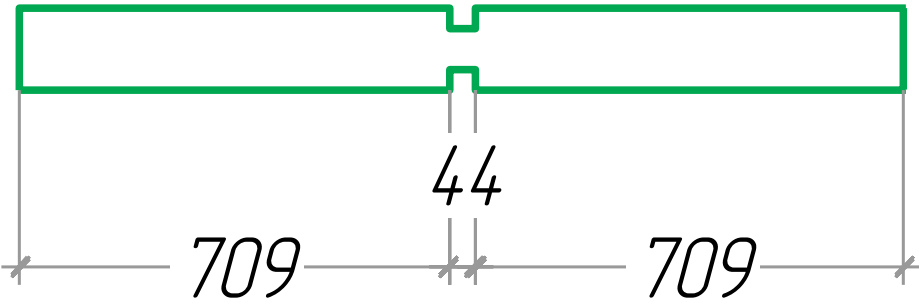
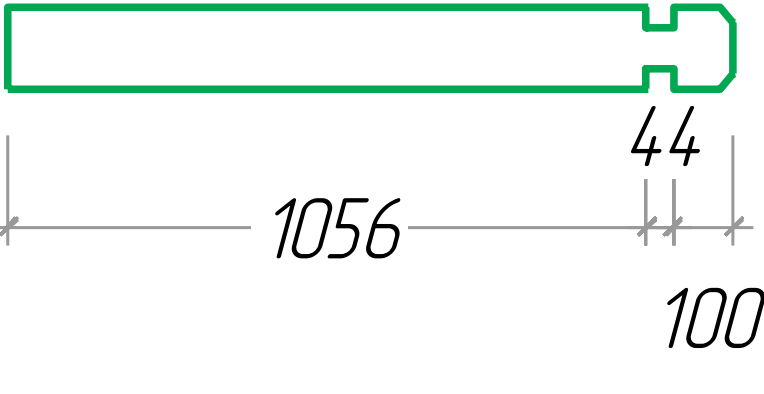
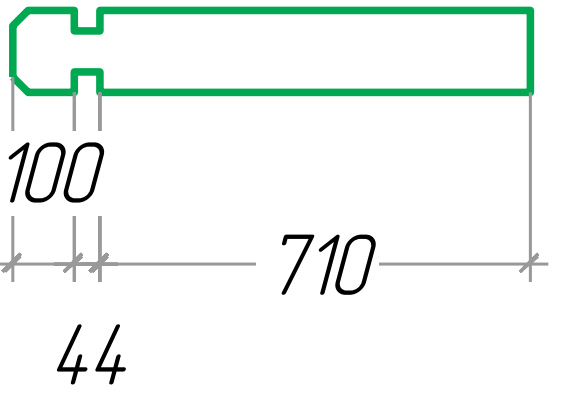
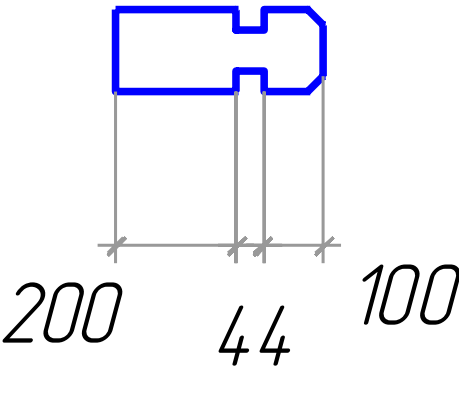
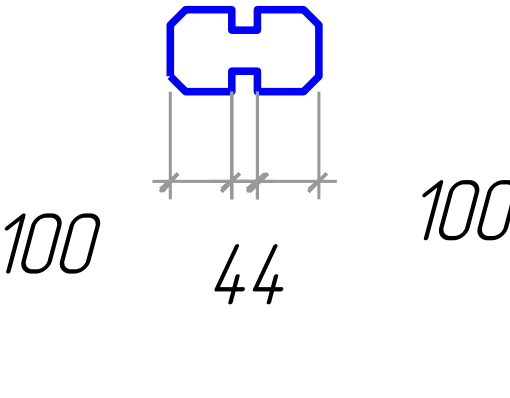

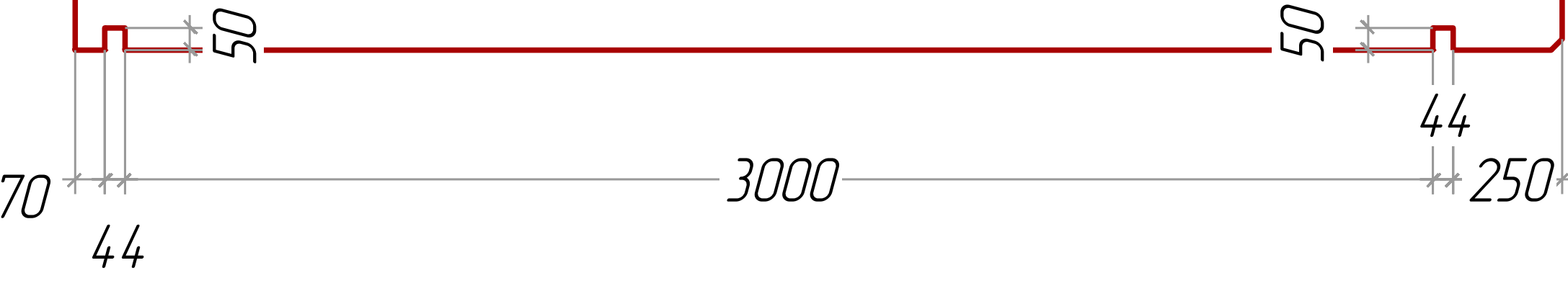
Plan of the floor board  
Plan der Furbodenbretter  
Le plan des plaches du plancher

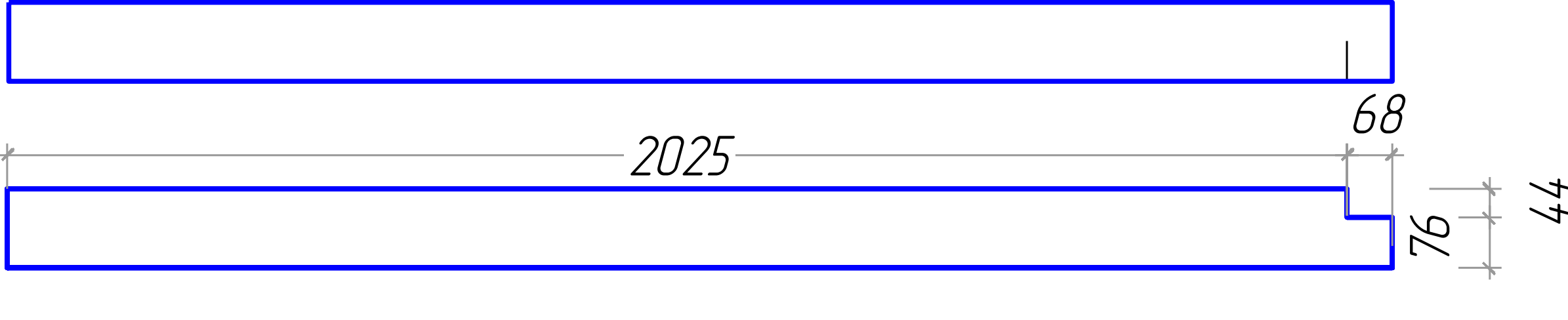



Nº	Alex 44 6x6	Nr.	Profile (mm)	Lenght (mm)
1		1	44x62.1	3206mm
2		1	44x67.5	3790mm
3		1	44x67.5	3104mm
4		2	44x67.5	2975mm
5		1	44x67.5	2026mm
6		1	44x72.3	3316mm
7		1	44x72.3	3084mm
8		7	44x135	3790mm
12		3	44x135	3668mm
13		1	44x135	3316mm
14		1	44x135	3316mm
15		1	44x135	3316mm
16		15	44x135	3288mm

Nº	Alex 44 6x6	Nr.	Profile (mm)	Lenght (mm)
18		1	44x135	3206mm
19		17+1	44x135	3166mm
20		14	44x135	3104mm
21		1	44x135	3084mm
22		1	44x135	3084mm
23		1	44x135	3084mm
24		1	44x135	3056mm
25		16	44x135	2975mm
27		1	44x135	2934mm
28		1	44x135	2934mm
29		1	44x135	2906mm
30		3	44x135	2906mm
31		15+1	44x135	2784mm

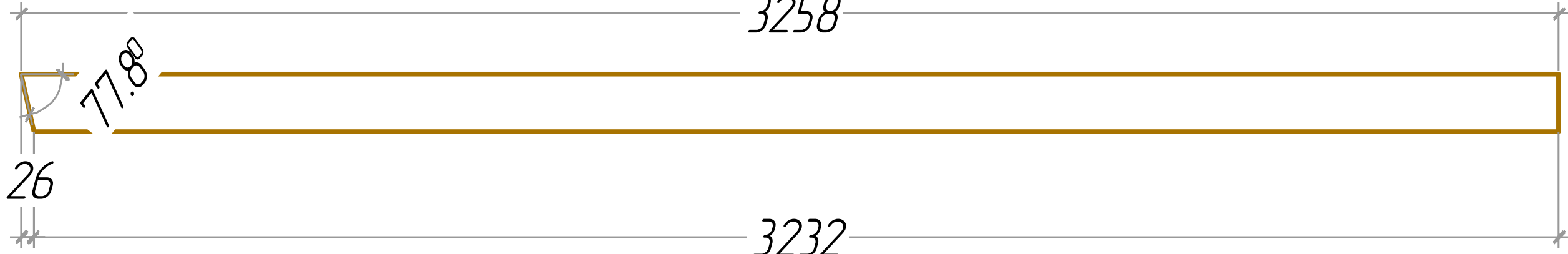
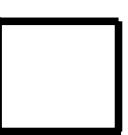
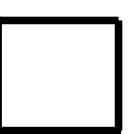
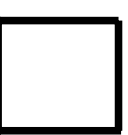
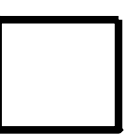
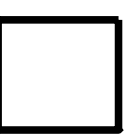
Nº	Alex 44 6x6	Nr.	Profile (mm)	Length (mm)
36		3	44x135	2282mm
37		14	44x135	2026mm
39		14	44x135	1742mm
40		8	44x135	1462mm
42		16	44x135	1200mm
43		16	44x135	854mm
44		14	44x135	344mm
45		20	44x135	244mm
46	<p>Foundation Fundament Salive</p> 	4	44x68	2870mm
47	<p>Foundation Fundament Salive</p> 	32	44x68	2826mm
48	<p>Roof beam. Dachbalken. Panne</p> 	4	44x140	3408mm
49	<p>Roof beam. Dachbalken. Panne</p> 	4	44x140	3176mm
50		1	120x120	2092mm

Nº	Alex 44 6x6		Nr.	Profile (mm)	Lenght (mm)
51	Roof side boards Traufenbrett Planche de rive		6	18x90	2133mm
52	Roof boards. Dachbretter Valige		112+1	20x115	3227mm
53	Floor boards Fu ssboden Lame de plancher		8+1	20x115	3020mm
54	Floor boards Fu ssboden Lame de plancher		42	20x115	2996mm
55	Floor boards Fu ssboden Lame de plancher		8+1	20x115	2638mm
56	Floor boards Fu ssboden Lame de plancher		23	20x115	2614mm
57	Floor boards Fu ssboden Lame de plancher		18+1	20x120	2655mm
58	Fascia board Giebelblende Planch de rive facade		4	20x120	3258mm
59	Floor edge trim Fu bleisten Plinthe plancher		1	18x20	3502mm
60	Floor edge trim Fu bleisten Plinthe plancher		2	18x20	3000mm
61	Floor edge trim Fu bleisten Plinthe plancher		2	18x20	2809mm
62	Floor edge trim Fu bleisten Plinthe plancher		1	18x20	2618mm
63	Floor edge trim Fu bleisten Plinthe plancher		1	18x20	2116mm

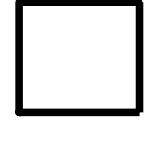
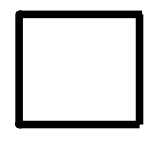
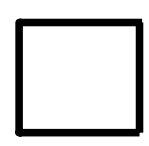
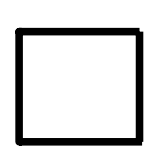
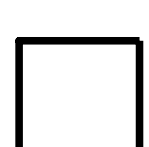
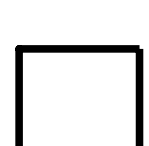
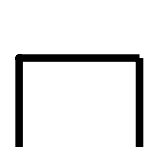
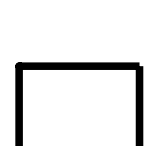

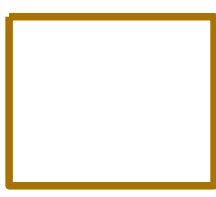
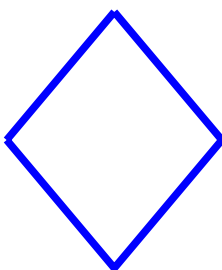
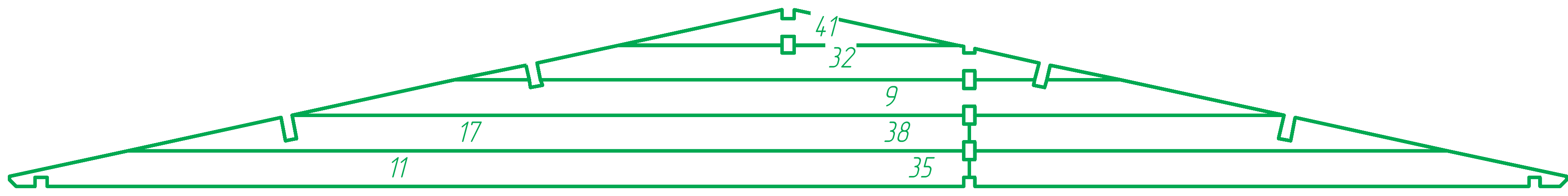
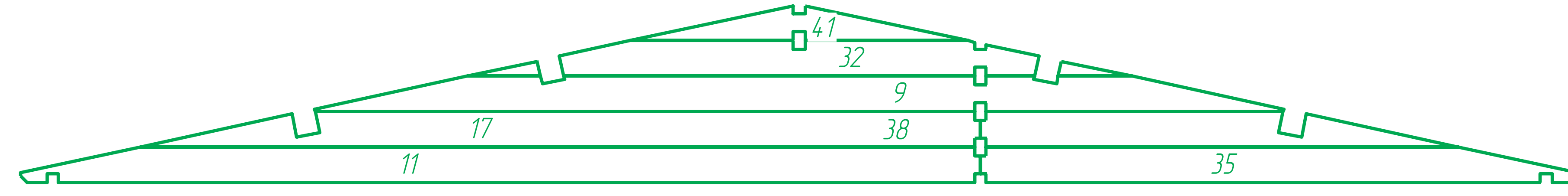
Nº	Alex 44 6x6	Nr.	Profile (mm)	Lenght (mm)
64	Floor edge trim Fu bleisten Plinthe plancher 	1	18x20	1839mm
65	Floor edge trim Fu bleisten Plinthe plancher 	1	18x20	1829mm
66	Floor edge trim Fu bleisten Plinthe plancher 	1	18x20	1555mm
67	Floor edge trim Fu bleisten Plinthe plancher 	1	18x20	757mm
68	Floor edge trim Fu bleisten Plinthe plancher 	1	18x20	747mm
69	Floor edge trim Fu bleisten Plinthe plancher 	1	18x20	157mm
70	Floor edge trim Fu bleisten Plinthe plancher 	4	18x20	118mm
71	Floor edge trim Fu bleisten Plinthe plancher 	2	18x20	80mm
72	Roofing felt fillet Giebelabschlussbrett Latte de finition couverture 	4	58x20	3253mm
73	Roof edge reinforcement Traufenleiste Tasseau 	6	28x34	2133mm
74	Diamond Raute Diamant 	2	20x120	120mm
W1		1		
W2		1		

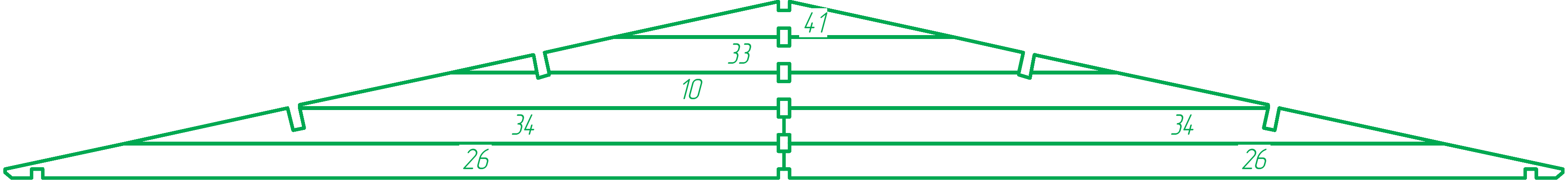
Nº	Alex 44 6x6	Nr.	Profile (mm)	Lenght (mm)
W3		1		
	Door Tur 1958x820 mm La porte	2		
	Window Fenetre 1080x1390 mm Fenster	3		

